

N-Channel MOSFET

IRF540NS (KRF540NS)

■ Features

- $V_{DS} (V) = 100V$
- $I_D = 33 A (V_{GS} = 10V)$
- $R_{DS(ON)} < 44m\Omega (V_{GS} = 10V)$
- Fast Switching

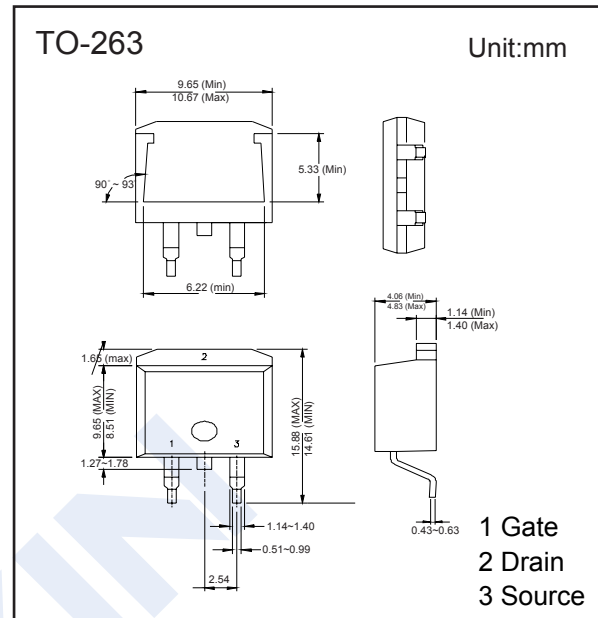
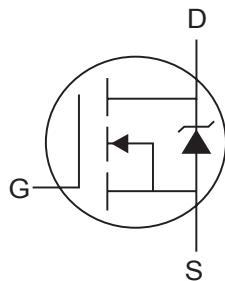

■ Absolute Maximum Ratings $T_a = 25^\circ C$

Parameter	Symbol	Rating	Unit	
Drain-Source Voltage	V_{DS}	100	V	
Gate-Source Voltage	V_{GS}	± 20		
Continuous Drain Current	I_D	$T_a=25^\circ C$	33	A
		$T_a=70^\circ C$	23	
Pulsed Drain Current	I_{DM}	110		
Avalanche Current	I_{AR}	16	A	
Repetitive Avalanche Energy	E_{AR}	13	mJ	
Peak Diode Recovery dv/dt	dv/dt	7	V/ns	
Power Dissipation	P_D	$T_c=25^\circ C$	130	W
Linear Derating Factor			0.87	
Thermal Resistance.Junction- to-Ambient	R_{thJA}	40	$^\circ C/W$	
Thermal Resistance.Junction- to-Case	R_{thJC}	1.15		
Junction Temperature	T_J	175	$^\circ C$	
Storage Temperature Range	T_{stg}	-55 to 175		

N-Channel MOSFET

IRF540NS (KRF540NS)

■ Electrical Characteristics $T_a = 25^\circ\text{C}$

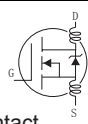
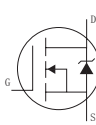
Parameter	Symbol	Test Conditions	Min	Typ	Max	Unit
Drain-Source Breakdown Voltage	V_{DS}	$I_D=250\ \mu\text{A}$, $V_{GS}=0\text{V}$	100			V
Zero Gate Voltage Drain Current	I_{DSS}	$V_{DS}=100\text{V}$, $V_{GS}=0\text{V}$			25	μA
		$V_{DS}=80\text{V}$, $V_{GS}=0\text{V}$, $T_J=150^\circ\text{C}$			250	
Gate-Body Leakage Current	I_{GSS}	$V_{DS}=0\text{V}$, $V_{GS}=\pm 20\text{V}$			± 100	nA
Gate Threshold Voltage	$V_{GS(th)}$	$V_{DS}=V_{GS}$, $I_D=250\ \mu\text{A}$	2		4	V
Static Drain-Source On-Resistance	$R_{DS(on)}$	$V_{GS}=10\text{V}$, $I_D=16\text{A}$ (Note.1)			44	$\text{m}\Omega$
Forward Transconductance	g_{FS}	$V_{DS}=50\text{V}$, $I_D=16\text{A}$ (Note.1)	21			S
Input Capacitance	C_{iss}	$V_{GS}=0\text{V}$, $V_{DS}=25\text{V}$, $f=1\text{MHz}$		1960		pF
Output Capacitance	C_{oss}			250		
Reverse Transfer Capacitance	C_{rss}			40		
Total Gate Charge	Q_g	$V_{GS}=10\text{V}$, $V_{DS}=80\text{V}$, $I_D=16\text{A}$ (Note.1)			71	nC
Gate Source Charge	Q_{gs}				14	
Gate Drain Charge	Q_{gd}				21	
Turn-On Delay Time	$t_{d(on)}$	$V_{GS}=10\text{V}$, $V_{DS}=50\text{V}$, $I_D=16\text{A}$, $R_G=5.1\ \Omega$ (Note.1)		11		ns
Turn-On Rise Time	t_r			35		
Turn-Off Delay Time	$t_{d(off)}$			39		
Turn-Off Fall Time	t_f			35		
Body Diode Reverse Recovery Time	t_{rr}	$I_F=16\text{A}$, $di/dt=100\text{A}/\mu\text{s}$, $T_J=25^\circ\text{C}$		115	170	nC
Body Diode Reverse Recovery Charge	Q_{rr}			505	760	
Internal Drain Inductance	L_D	Between lead, 6mm (0.25in.) from package and center of die contact 		4.5		nH
Internal Source Inductance	L_S			7.5		
Single Pulse Avalanche Energy	E_{AS}	$I_{AS}=16\text{A}$, $L=1.5\text{mH}$			185	mJ
Maximum Body-Diode Continuous Current	I_S	MOSFET symbol showing the integral reverse p-n junction diode. 			33	A
Pulsed Source Current	I_{SM}				110	
Diode Forward Voltage	V_{SD}	$I_S=16\text{A}$, $V_{GS}=0\text{V}$, $T_J=25^\circ\text{C}$			1.2	V

Note.1: Pulse width $\leq 400\ \mu\text{s}$; duty cycle $\leq 2\%$.

N-Channel MOSFET IRF540NS (KRF540NS)

■ Typical Characteristics

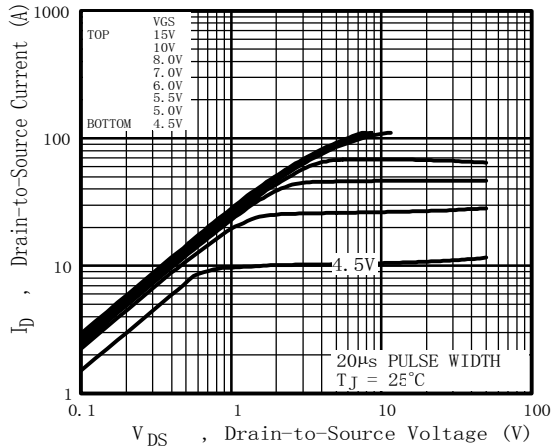

Fig 1. Typical Output Characteristics

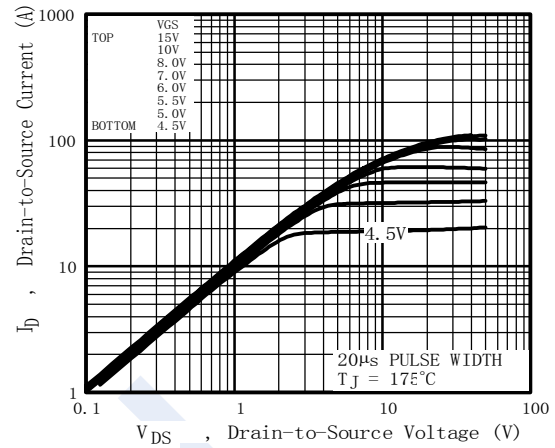

Fig 2. Typical Output Characteristics

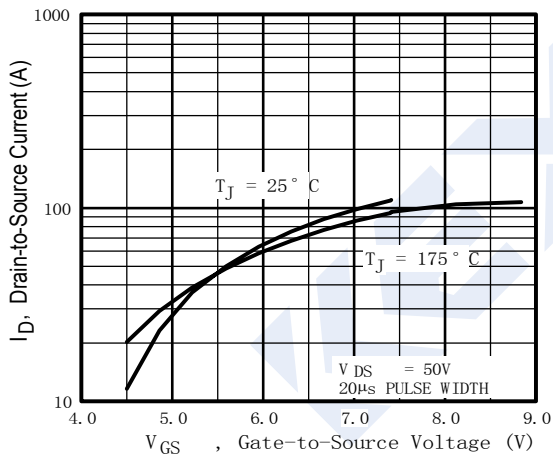

Fig 3. Typical Transfer Characteristics

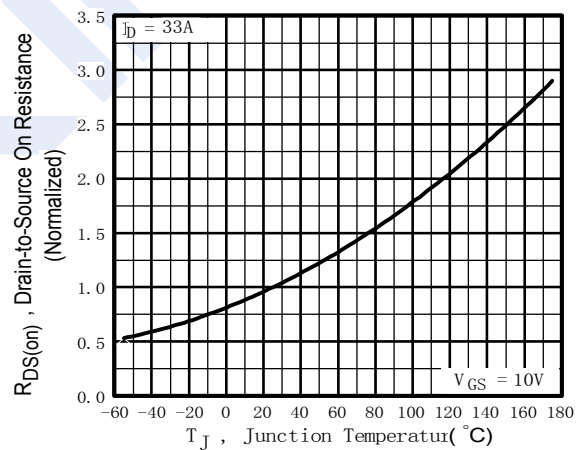

Fig 4. Normalized On-Resistance Vs. Temperature

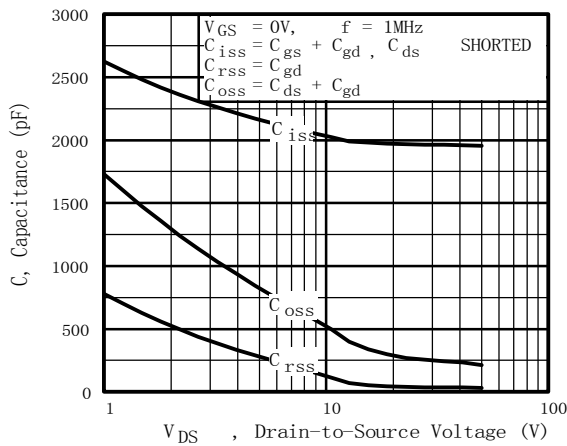

Fig 5. Typical Capacitance Vs. Drain-to-Source Voltage

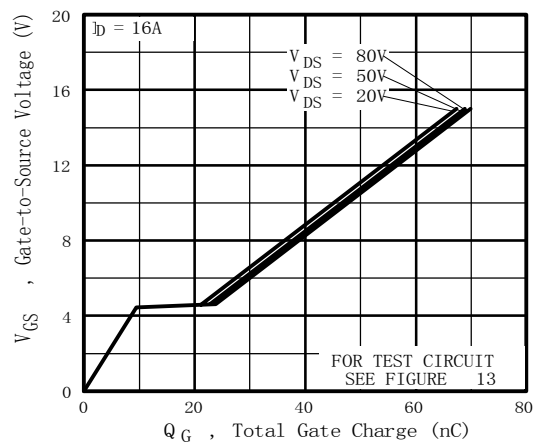

Fig 6. Typical Gate Charge Vs. Gate-to-Source Voltage

N-Channel MOSFET IRF540NS (KRF540NS)

■ Typical Characteristics

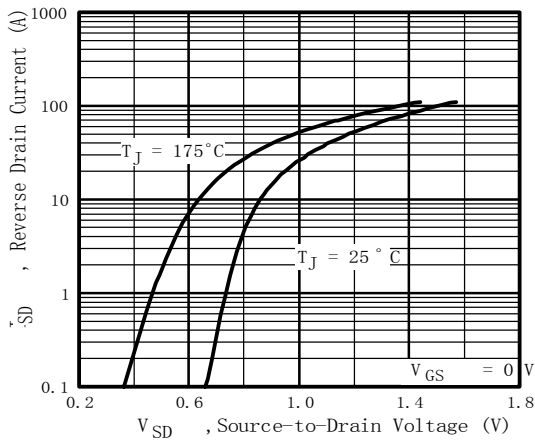

Fig 7. Typical Source-Drain Diode Forward Voltage

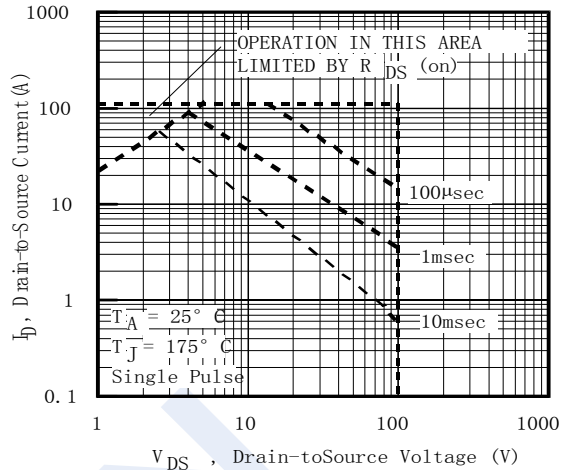

Fig 8. Maximum Safe Operating Area

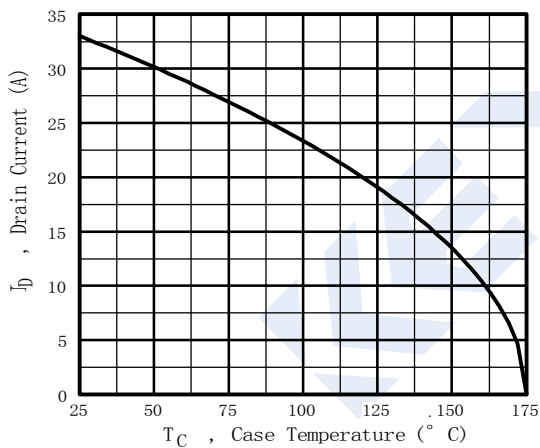

Fig 9. Maximum Drain Current Vs. Case Temperature

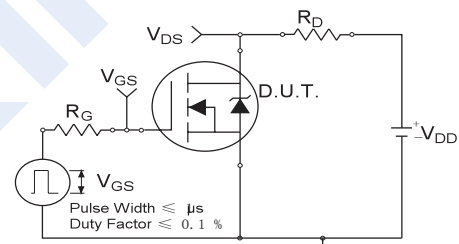

Fig 10a. Switching Time Test Circuit

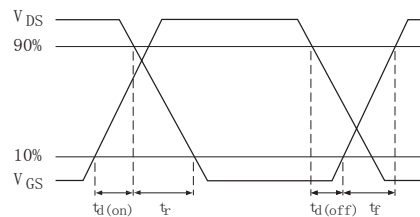

Fig 10b. Switching Time Waveforms

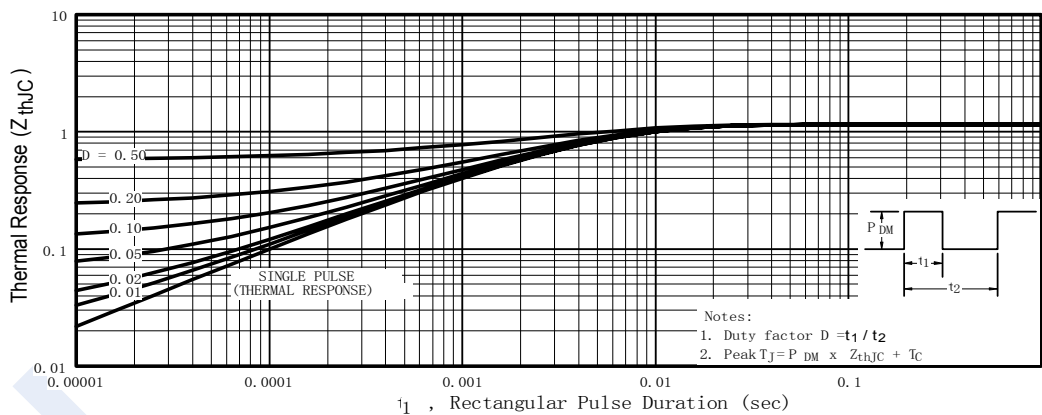

Fig 11. Maximum Effective Transient Thermal Impedance, Junction-to-Case

N-Channel MOSFET IRF540NS (KRF540NS)

■ Typical Characteristics

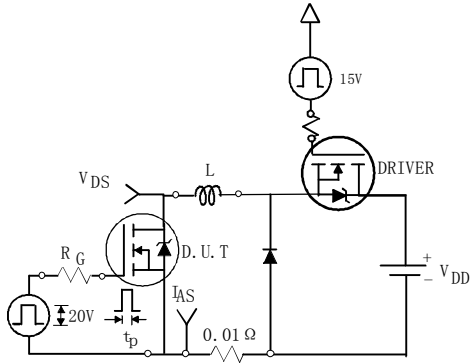

Fig 12a. Unclamped Inductive Test Circuit

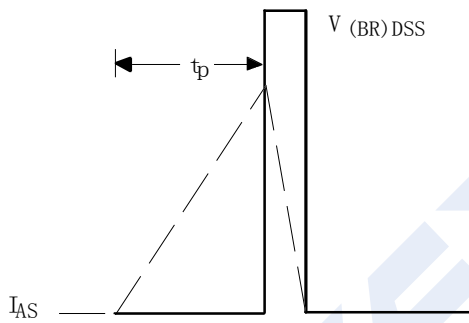

Fig 12b. Unclamped Inductive Waveforms

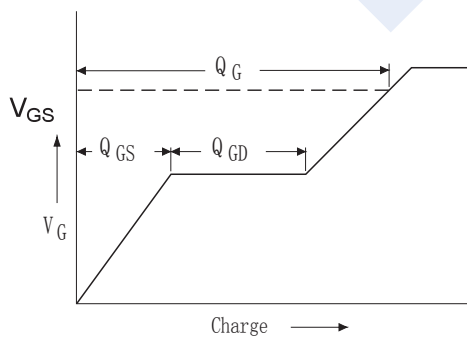

Fig 13a. Basic Gate Charge Waveform

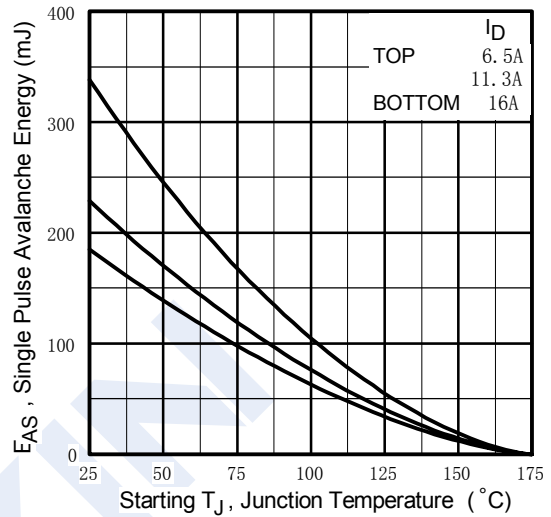

Fig 12c. Maximum Avalanche Energy Vs. Drain Current

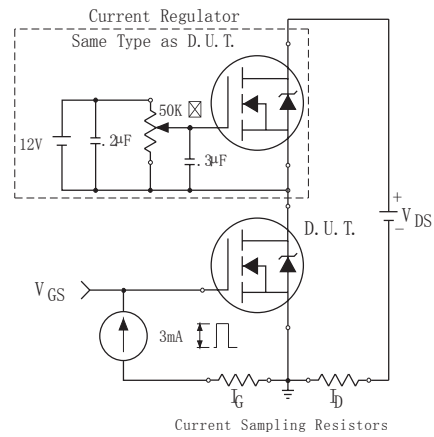
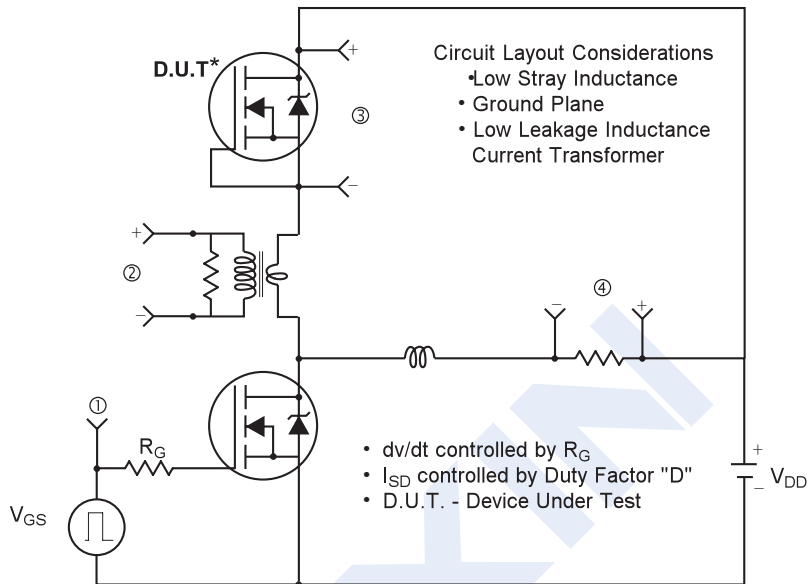

Fig 13b. Gate Charge Test Circuit

N-Channel MOSFET IRF540NS (KRF540NS)

■ Typical Characteristics

Peak Diode Recovery dv/dt Test Circuit



* Reverse Polarity of D.U.T for P-Channel

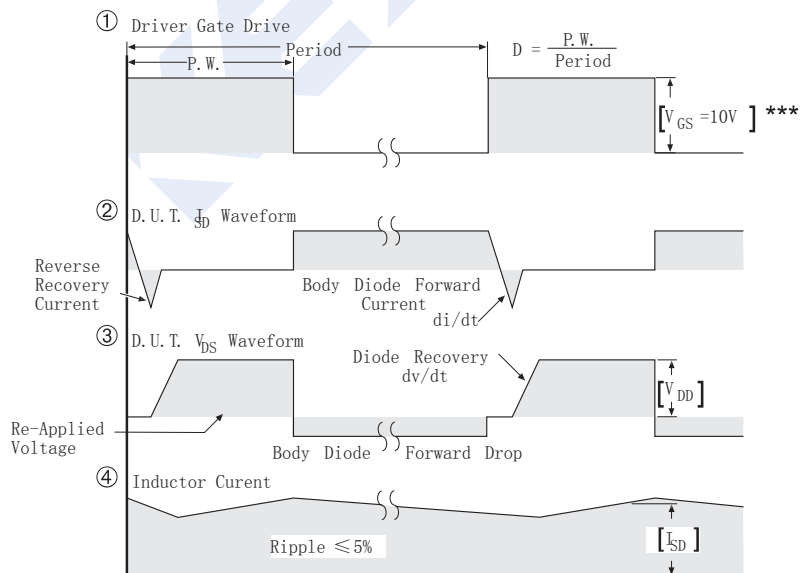

*** $V_{GS} = 5.0V$ for Logic Level and 3V Drive Devices

Fig 14. For N-channel HEXFET® power MOSFETs